

# Roller Spindle Fitting Instructions For Henderson Pre-Premiere

All work to be carried out from inside the garage.

Tools required: Screwdriver, 4mm pin punch, 1/4" dia toggle bar.

Note: You will need assistance when replacing and removing the crook pin. In order to ease the spring pressure place a 1/4" dia toggle bar into the hole in the spring plug as shown, and turn it upwards.

This will allow the crook pin to be inserted or removed.

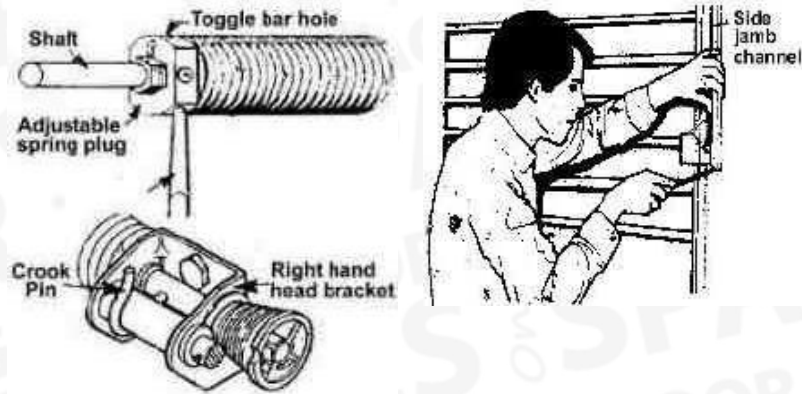

Removal and replacement instructions.

1. With the door in the closed position, insert the supplied crook pin through the shaft in the right hand head bracket to retain the spring tension as described in the note above.
2. Remove the screws at the base of the side jamb channels and move the channels outwards to release the roller spindle. Note: This may not be possible if the door jamb is close to a wall - it may be necessary to remove the door from the opening (see separate instructions opposite)
3. Remove the cable by passing the loop over the roller, prize-off the retaining circlips from the spindle. Note: pre 1981 type rollers were secured with a hex nut & washer
4. Withdraw the spindle then re-install the new replacement and repeat the procedure on the other side. To replace simply reverse the above procedure

Note : You will need assistance when removing the crook pin. In order to ease the spring pressure place a toggle bar into the hole in the spring plug and turn it upwards and hold it while an assistant removes the crook pin using a screwdriver. Slowly lower the toggle bar whilst checking that both cables are routed correctly down the jamb channels and engaged correctly into the roller spindle groves.

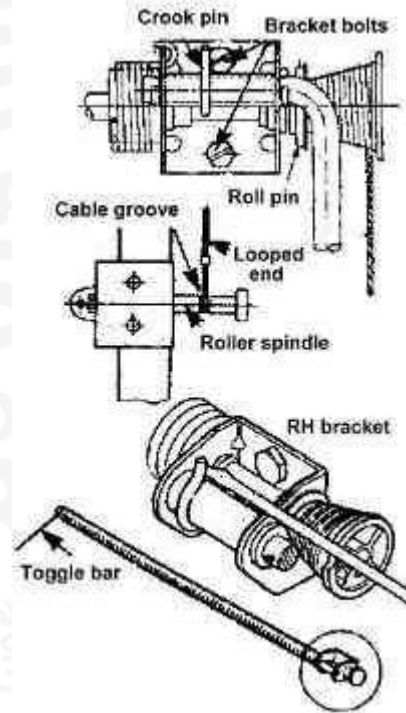

**Warning** - It is important that this instruction is followed correctly as personal injury, damage to cable or loss of pre-tension could occur.

5. Lubricate roller spindles, top latch and all other moving parts. To ensure continued ease of operation lubricate periodically.

Remove the door as follows:

- a. Insert the crook pin into right hand head bracket
- b. Wedge the door in the opening so it will not move
- c. Unscrew and remove the side jamb channels
- d. Remove the head bracket bolt and lower the spring
- e. Lift the door from the opening

All work is undertaken at your own risk.

SKU: HES4050, HES4060, HES4070